

TRI-PAK T-500 SERIES COMPACTORS

MECHANICAL

| | T-500 | T-500HD | T-500XHD | T-500X |
|-----------------------------|---------------|---------------|---------------|---------------|
| CHARGE CHAMBER VOLUME | 5.0 | 5.0 | 5.0 | 5.0 |
| CHARGE CHAMBER OPENING SIZE | 84" x 60" | 84" x 60" | 84" x 60" | 84" x 60" |
| RAM FACE SIZE | 36" x 60" | 36" x 60" | 36" x 60" | 36" x 60" |
| RAM PENETRATION | 24" | 24" | 24" | 24" |
| COMPACTION FORCE NORMAL | 56,500 lbs | 76,930 lbs | 113,000 lbs | 63,585 lbs |
| COMPACTION FORCE MAXIMUM | 64,975 lbs | 88,470 lbs | 124,344 lbs | 69,945 lbs |
| CYCLE TIME | 63 seconds | 73 seconds | 63 seconds | 63 seconds |
| SYSTEM PRESSURE NORMAL | 2,000 psi | 2,000 psi | 2,000 psi | 2,000 psi |
| SYSTEM PRESSURE MAXIMUM | 2,200 psi | 2,200 psi | 2,200 psi | 2,200 psi |
| PUMP CAPACITY | 20 gpm | 25 gpm | 30 gpm | 20 gpm |
| MOTOR SIZE | 20 hp | 25 hp | 30 hp | 20 hp |
| CYLINDER SIZE | 1 x 6"Ø | 1 x 7"Ø | 2 x 6"Ø | 2 x 5"Ø |
| CYLINDER TYPE | Double Acting | Double Acting | Double Acting | Double Acting |
| RAM FACE PRESSURE NORMAL | 34.2 psi | 46.6 psi | 68.5 psi | 38.5 psi |
| RAM FACE PRESSURE MAXIMUM | 39.4 psi | 53.6 psi | 78.8 psi | 42.4 psi |
| OIL TANK CAPACITY | 50 gal | 75 gal | 95 gal | 50 gal |
| SHIPPING WEIGHT | 11,350 lbs | 12,950 lbs | 14,875 lbs | 11,350 lbs |

ELECTRICAL

| | |
|----------------|---|
| CONTROL SYSTEM | 110 VOLT 60 CYCLE POWERED BY STEP-DOWN TRANSFORMER |
| CONTROL PANEL | FULLY WIRED. KEYED START BUTTON, EMERGENCY STOP, FULL LIGHT, RESET BUTTON, PLC, CURRENT SENSOR |
| POWER | 208/230/575 VOLT, 3 PHASE 60 CYCLE |

DIMENSIONS

| | A | B | C | D | E |
|----------|------|-----|-----|-----|-----|
| T-500 | 212" | 48" | 72" | 84" | 60" |
| T-500HD | 212" | 48" | 72" | 84" | 60" |
| T-500XHD | 212" | 48" | 72" | 84" | 60" |
| T-500X | 186" | 48" | 72" | 84" | 60" |

STANDARD FEATURES

- ▶ CSA Approved Design
- ▶ Heavy Duty Oil - tight Pushbutton Controls
- ▶ Key Lockable Start Pushbutton
- ▶ Automatic Multi - cycle Operation
- ▶ PLC Controlled System
- ▶ Full - Container Light

OPTIONAL EQUIPMENT

- ▶ Advance - warning Light
- ▶ Fluid - filled Pressure Gauge
- ▶ Oil Heater
- ▶ Odor Control System
- ▶ Open Hopper -(for top or dock loading)
- ▶ Fully Enclosed Hopper with Door
- ▶ Through the Wall Installation Kits
- ▶ Walk-on or Drive-on Decks
- ▶ Safety Gate
- ▶ Hydraulic Cart-dump Systems

This Equipment is CSA Approved and
Conforms to all Current ANSI Z245.2
Safety Standards.

In order to provide the most currently engineered and designed
equipment, We reserve the right to change specifications without notice.
This brochure is intended to provide information only, and should not
be used in an arbitrary manner to judge equipment for any particular purpose.

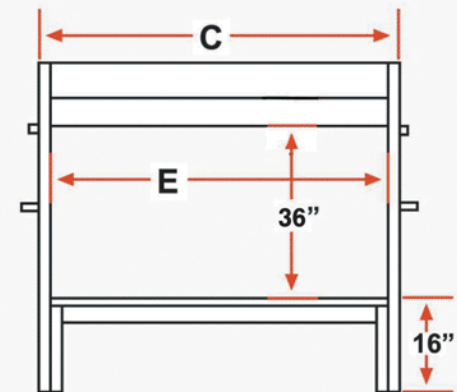
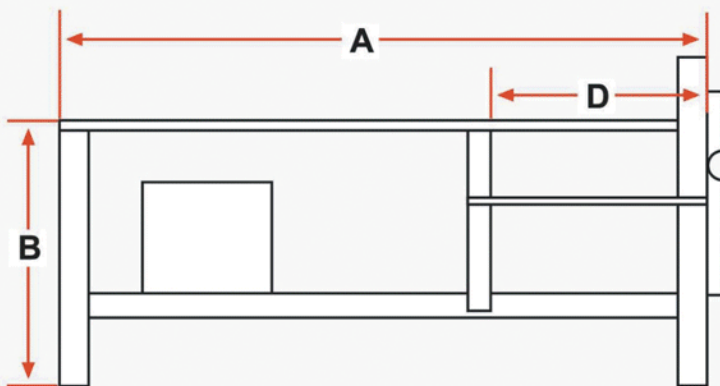

REACTION
DISTRIBUTING INC.
THE TREND SETTERS

DISTRIBUTED BY: