

TRI-PAK APARTMENT COMPACTOR

MECHANICAL

	T-20X			
CHARGE CHAMBER VOLUME	0.25			
CHARGE CHAMBER OPENING SIZE	27" x 25"			
RAM FACE SIZE	27" x 15"			
RAM PENETRATION	5"			
COMPACTION FORCE NORMAL	19,625 lbs			
COMPACTION FORCE MAXIMUM	23,550 lbs			
CYCLE TIME	25 seconds			
SYSTEM PRESSURE NORMAL	2000 psi			
SYSTEM PRESSURE MAXIMUM	2200 psi			
PUMP CAPACITY	2 gpm			
MOTOR SIZE	1 hp			
CYLINDER SIZE	2 x 2.5"			
CYLINDER TYPE	Double Acting			
RAM FACE PRESSURE NORMAL	48.5 psi			
RAM FACE PRESSURE MAXIMUM	58.1 psi			
OIL TANK CAPACITY	5 gal			
SHIPPING WEIGHT	950 lbs			

ELECTRICAL

CONTROL SYSTEM	110 VOLT 60 CYCLE POWERED BY STEP-DOWN TRANSFORMER
CONTROL PANEL	FULLY WIRED. KEYED START BUTTON, EMERGENCY STOP, FULL LIGHT, RESET BUTTON, PLC, CURRENT SENSOR
POWER	115 VOLT, SINGLE PHASE

DIMENSIONS

	A	B	C	D	E
T-20X	52"	34"	31"	25"	27"

STANDARD FEATURES

- ▶ CSA Approved Design
- ▶ Heavy Duty Oil - tight Pushbutton Controls
- ▶ Automatic "Timed" Cycle Start
- ▶ Automatic Multi - cycle Operation
- ▶ PLC Controlled System
- ▶ Full - Container Light

OPTIONAL EQUIPMENT

- ▶ Advance - warning Light
- ▶ Fluid - filled Pressure Gauge
- ▶ Oil Heater
- ▶ Odor Control System
- ▶ Open Hopper -(for top or dock loading)
- ▶ Remote Trouble / Fill Light
- ▶ Sorter System

This Equipment is CSA Approved and
Conforms to all Current ANSI Z245.2
Safety Standards.

In order to provide the most currently engineered and designed
equipment, We reserve the right to change specifications without notice.
This brochure is intended to provide information only, and should not
be used in an arbitrary manner to judge equipment for any particular purpose.

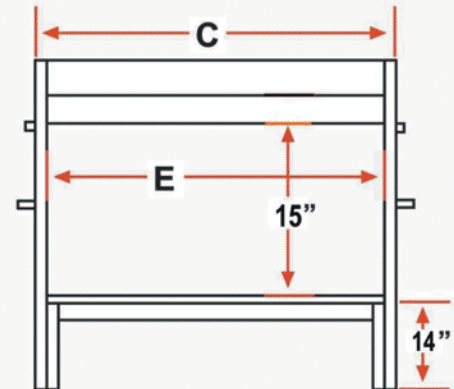
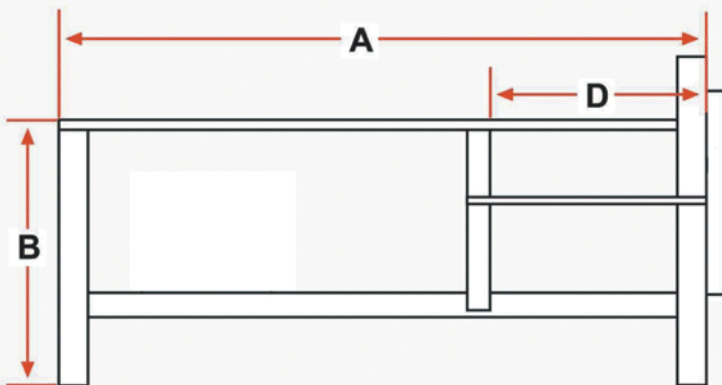

DISTRIBUTED BY:

REACTION
DISTRIBUTING INC.
THE TREND SETTERS

44 Spiers Crescent, Ajax, Ontario L1S 6Y7 Tel: 905-426-6442 Fax: 905-426-5925 www.balers.ca