

# TRI-PAK VERTICAL COMPACTOR

## MECHANICAL

	TV3000-6	TV3000-8
CHARGE CHAMBER VOLUME	1 cu yd	1 cu yd
CHARGE CHAMBER OPENING SIZE	33" x 48"	33" x 48"
RAM FACE SIZE	48" x 34"	48" x 34"
RAM PENETRATION	29.5"	29.5"
COMPACTION FORCE NORMAL	28,260 lbs	28,260 lbs
COMPACTION FORCE MAXIMUM	33,912 lbs	33,912 lbs
CYCLE TIME	34 seconds	34 seconds
SYSTEM PRESSURE NORMAL	2000 psi	2000 psi
SYSTEM PRESSURE MAXIMUM	2400 psi	2400 psi
PUMP CAPACITY	1gpm/3 gpm	1gpm/3 gpm
MOTOR SIZE	1hp/3 hp	1hp/3 hp
CYLINDER SIZE	2 x 3"	2 x 3"
CYLINDER TYPE	Double Acting	Double Acting
RAM FACE PRESSURE NORMAL	17.4 psi	17.4 psi
RAM FACE PRESSURE MAXIMUM	20.8 psi	20.8 psi
OIL TANK CAPACITY	5 gal	5 gal
SHIPPING WEIGHT (HEAD ONLY)	1485 lbs	1485 lbs

## ELECTRICAL

CONTROL SYSTEM	110 VOLT 60 CYCLE POWERED BY STEP-DOWN TRANSFORMER
CONTROL PANEL	FULLY WIRED. KEYED START BUTTON, EMERGENCY STOP, FULL LIGHT, RESET BUTTON, PLC, CURRENT SENSOR
POWER	208/575 VOLT-3 PHASE, 115/230 VOLT-SINGLE PHASE

## STANDARD FEATURES

- ▶ CSA Approved Design
- ▶ Heavy Duty Oil - tight Pushbutton Controls
- ▶ Automatic Single - cycle Operation
- ▶ PLC Controlled System
- ▶ Full - Container Light

## OPTIONAL EQUIPMENT

- ▶ Advance - warning Light
- ▶ Fluid - filled Pressure Gauge
- ▶ Oil Heater
- ▶ Odor Control System

This Equipment is CSA Approved and  
Conforms to all Current ANSI Z245.2  
Safety Standards.

In order to provide the most currently engineered and designed  
equipment, We reserve the right to change specifications without notice.  
This brochure is intended to provide information only, and should not  
be used in an arbitrary manner to judge equipment for any particular purpose.

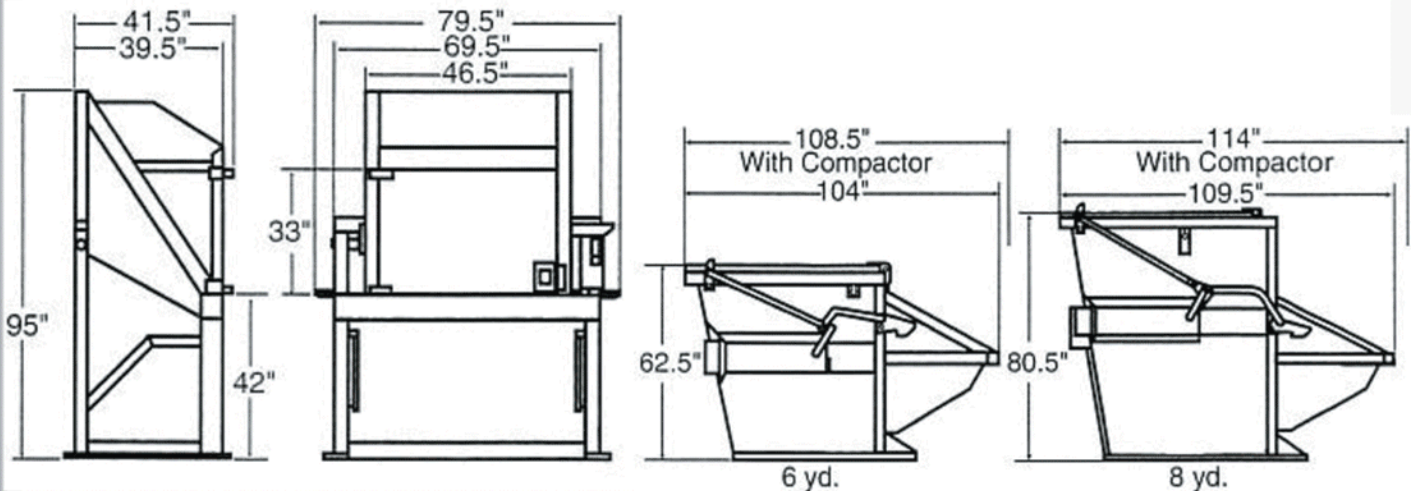

DISTRIBUTED BY:

**REACTION**  
DISTRIBUTING INC.  
**THE TREND SETTERS**

44 Spiers Crescent, Ajax, Ontario L1S 6Y7 Tel: 905-426-6442 Fax: 905-426-5925 www.balers.ca